

JOC-61BA

COMPLEJO "ESTELAR" CON TOBOGÁN INOX
COMBINATION "STAR", SLIDE OF STAINLESS STEEL
COMBINAISON "ÉTOILE", TOBOGGAN INOX

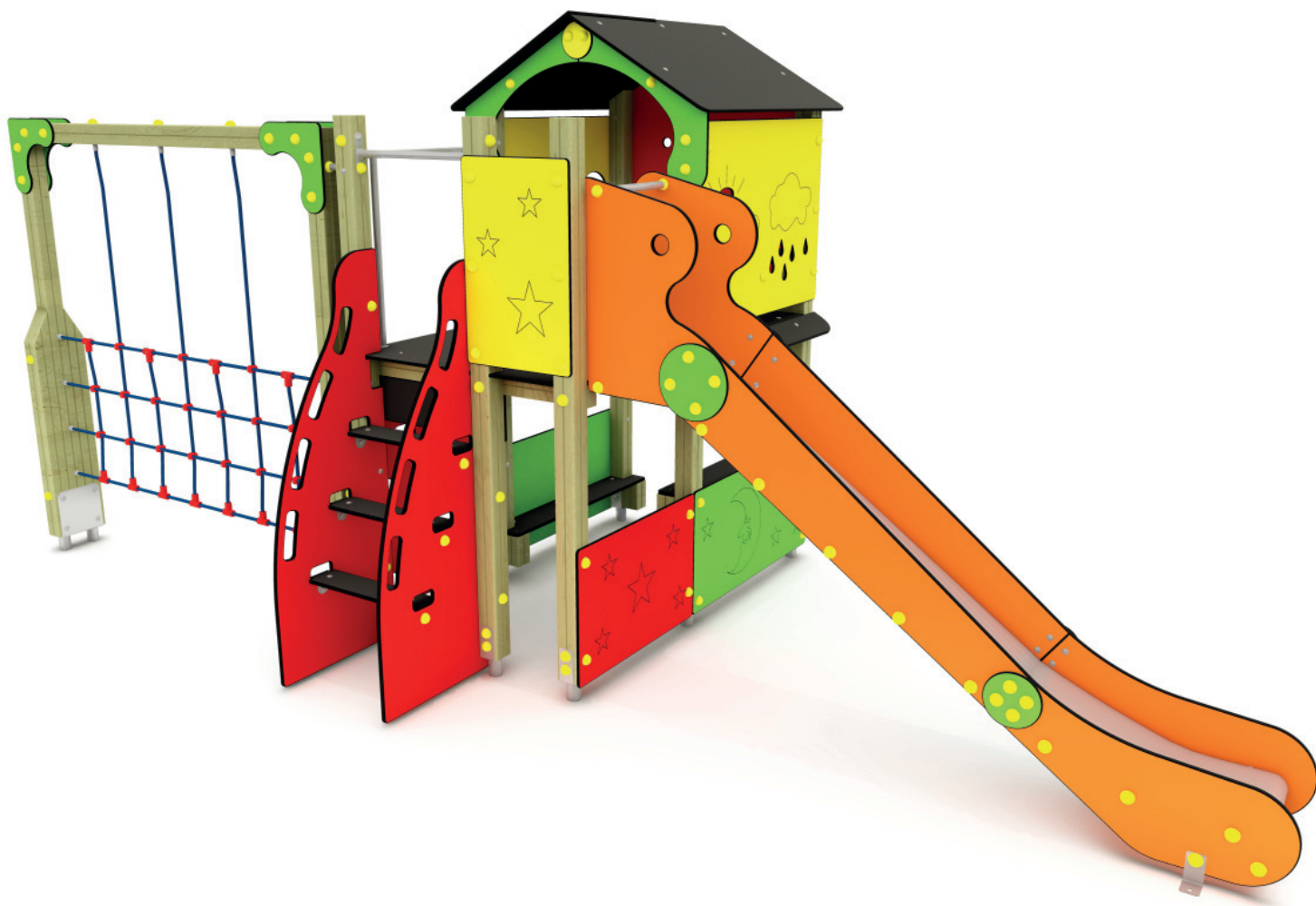

Características

Characteristics
Caractéristiques



EN 1176



+ 3 años



Nº
32 u.



609 x 279 x 273 cm.



130 cm.



37,40 m²

* Estructura

Structure
Structure

Madera laminada de pino de Suecia tratada en autoclave

Laminated Swedish pinewood autoclave treated

Bois lamellé de pin suédois traité en autoclave

* Paneles

Panels
Panneaux

HDPE (Polietileno de alta densidad) de 13 y 19 mm.

HDPE (High-density polyethylene) 13 and 19 mm.

PEHD (Polyéthylène de haute densité) 13 et 19 mm.

* Deslizador

Sliding sole
Glissière

Acero Inoxidable 130 cm.

Stainless Steel 130 cm.

Acier Inoxydable 130 cm.

* Plataformas y Peldaños

Platforms and steps
Plateformes et marches

Contrachapado Fenólico Antideslizante de 15 y 18 mm.

Phenolic nonslip plywood 15 and 18 mm.

Contreplaqué Phenolique Antiglissant 15 et 18 mm.

es

Estructura formada por una torre a dos alturas, con cubierta a dos aguas y plataforma a la que se puede acceder, bien mediante una escalera inclinada de Polietileno de 19 mm., o bien mediante un panel trepa. Lateralmente a esta estructura existe una red de trepa. En la parte inferior de la torre se ubica una pequeña tienda con mostrador y banquito. En la parte superior de la torre se incluye el tobogán de deslizamiento y una pequeña cabaña con asientos.

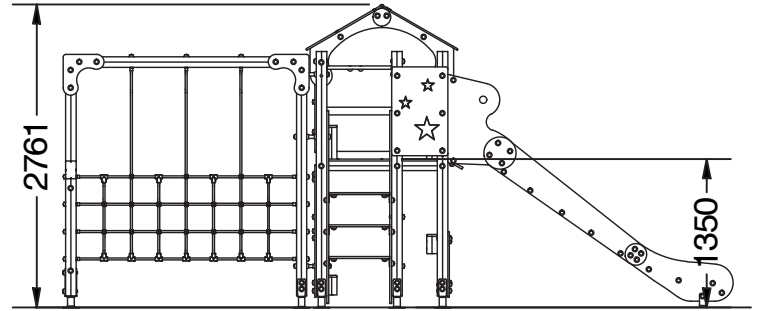

en

Playground structure formed by a two-storey tower covered with a ridge roof.

Access to the platform either with stairs whose lateral panels are made of 19 mm. polyethylene or with the aid of a climbing panel. On the ground floor of the tower there is a shop-like playhouse with counter and bench. On the upper floor of the tower there is the slide for descending and also a small playing hut with seats. On the side of the playing structure there is an additional climbing frame.

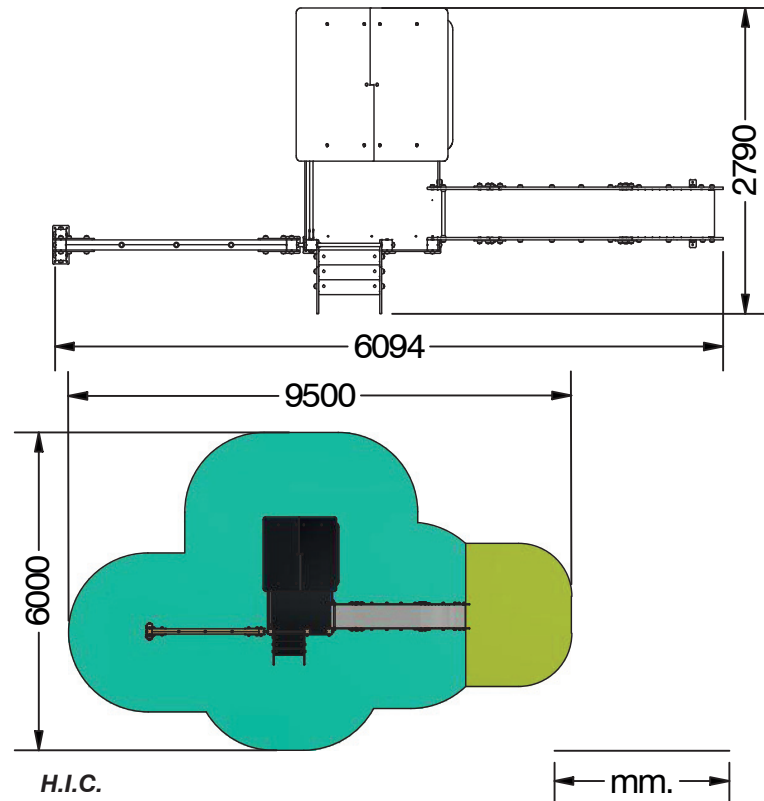

fr

Structure formée d'une tour de deux niveaux, avec toiture à deux pentes et une plateforme à laquelle on peut accéder soit au moyen d'un escalier incliné fabriqué en panneau de polyéthylène de 19 mm. soit au moyen d'un mur à grimper. Dans la partie inférieure de la tour se trouve une petite boutique avec un comptoir et des petits bancs. Sur la partie supérieure de la tour est fixé le toboggan et une petite cabane avec des sièges. Latéralement à cette structure se trouve un filet à grimper.

H.I.C.

1000 mm. 5 m²

1300 mm. 32,40 m²

COMPLEJO "ESTELAR" CON TREPA
COMBINATION "STAR" WITH CLIMBING FRAME
COMBINAISON "ÉTOILE" AVEC FILET À GRIMPER

