

JOC-61B1

COMPLEJO "ESTELAR" SIN TREPA
COMBINATION "STAR" WITHOUT CLIMBING FRAME
COMBINAISON "ÉTOILE" SANS FILET À GRIMPER



Características

Characteristics
Caractéristiques



EN 1176



348 x 279 x 273 cm.



+ 3 años



130 cm.



Nº
25 u.



29,80 m²

* Estructura

Structure
Structure

Madera laminada de pino de Suecia tratada en autoclave

Laminated Swedish pinewood autoclave treated

Bois lamellé de pin suédois traité en autoclave

* Paneles

Panels
Panneaux

HDPE (Polietileno de alta densidad) de 13 y 19 mm.

HDPE (High-density polyethylene) 13 and 19 mm.

PEHD (Polyéthylène de haute densité) 13 et 19 mm.

* Deslizador

Sliding sole
Glissière

Polietileno 130 cm.

Polyethylene 130 cm.

Polyéthylène 130 cm.

* Plataformas y Peldaños

Platforms and steps
Plateformes et marches

Contrachapado Fenólico Antideslizante de 15 y 18 mm.

Phenolic nonslip plywood 15 and 18 mm.

Contreplaqué Phenolique Antiglissant 15 et 18 mm.

es

Estructura formada por una torre a dos alturas, con cubierta a dos aguas y plataforma de 2,10m x 1,20m en altura 1,30m. En la parte superior de la torre se ubica una casita con asientos, simulando una cabaña, a la que se puede acceder mediante una escalera o un panel de trepa perforado y descender mediante un tobogán.

En la parte inferior de la torre, se ubica una pequeña tienda con mostrador y banquito.

Seguro y anti-vandálico. Suministro posible montado o desmontado para envío paletizado.

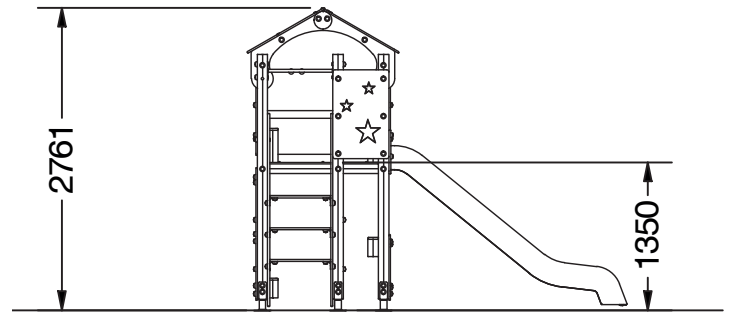

en

Playground structure formed by a two-storey tower, covered with a ridge roof and a platform of 2,10m x 1,20m with platform height 1,30m. On the upper floor of the tower there's a playhouse with seats imitating a hut. The play structure disposes of stairs and of a perforated climbing panel for the ascent and of a slide for the descent.

On the ground floor of the tower there is another playhouse with bench and counter imitating a shop.

Safe and vandal-proof. Delivery possible mounted or unmounted for palletised transport.

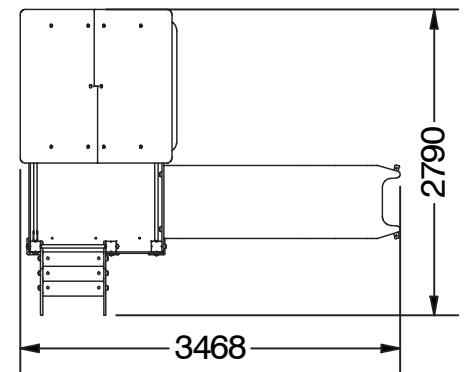

fr

Structure formée d'une tour de deux étages avec toiture à deux pentes et plateforme de 2,10m x 1,20m à l' hauteur 1,30m. À l'étage supérieur il se trouve une maisonette avec siège simulant une cabane, où on peut monter à travers escalier ou panneau perforé à grimper et descendre au moyen d'un toboggan.

À l'étage inférieur il se trouve une cabane avec banquette et comptoir simulant une petite boutique.

Sécurisé et anti-vandalique. Fourniture possible assemblé ou non-assemblé pour envoi palettisé.

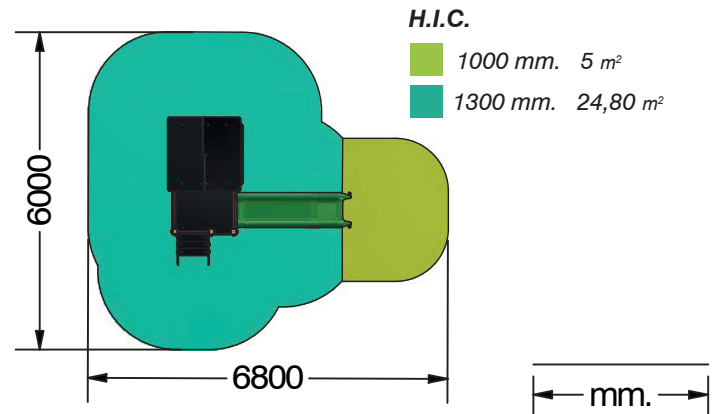

COMPLEJO "ESTELAR" SIN TREPA
COMBINATION "STAR" WITHOUT CLIMBING FRAME
COMBINAISON "ÉTOILE" SANS FILET À GRIMPER

